

VIII.6. Rate of Noise Pulses in Threshold Discriminator Systems

Noise affects not only the resolution of amplitude measurements, but also the determines the minimum detectable signal threshold.

Consider a system that only records the presence of a signal if it exceeds a fixed threshold.

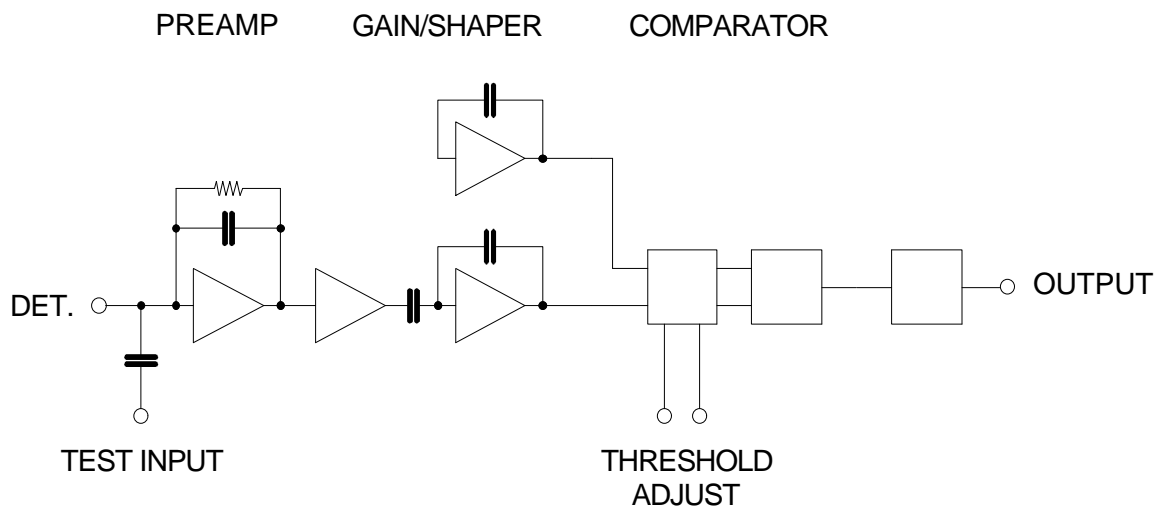

How small a detector pulse can still be detected reliably?

Consider the system at times when no detector signal is present.

Noise will be superimposed on the baseline.

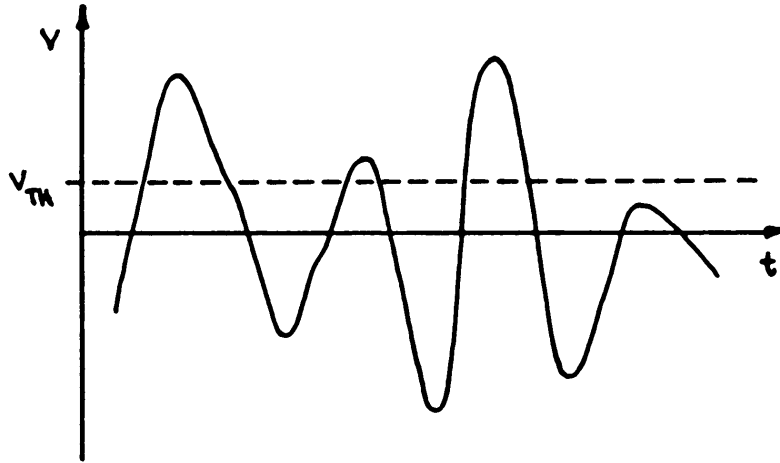

The amplitude distribution of the noise is gaussian.

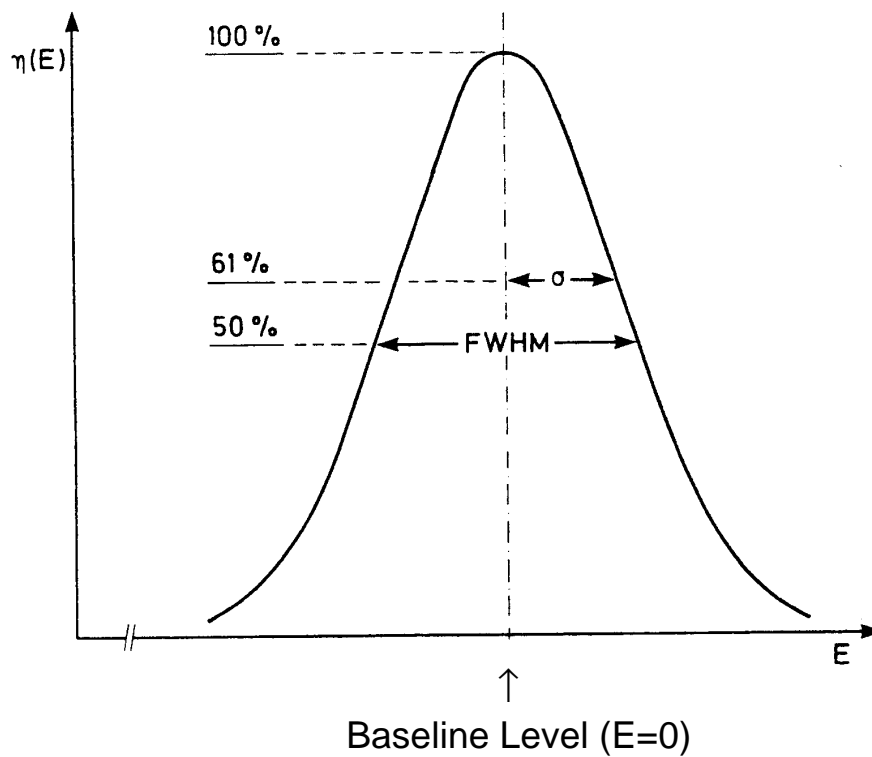

With the threshold level set to 0 relative to the baseline, all of the positive excursions will be recorded.

Assume that the desired signals are occurring at a certain rate.

If the detection reliability is to be >99%, then the rate of noise hits must be less than 1% of the signal rate.

The rate of noise hits can be reduced by increasing the threshold.

If the system were sensitive to pulse magnitude alone, the integral over the gaussian distribution (the error function) would determine the factor by which the noise rate f_{n0} is reduced.

$$\frac{f_n}{f_{n0}} = \frac{1}{Q_n \sqrt{2\pi}} \int_{Q_T}^{\infty} e^{-(Q/2Q_n)^2} dQ$$

where Q is the equivalent signal charge, Q_n the equivalent noise charge and Q_T the threshold level. However, since the pulse shaper broadens each noise impulse, the time dependence is equally important. For example, after a noise pulse has crossed the threshold, a subsequent pulse will not be recorded if it occurs before the trailing edge of the first pulse has dropped below threshold.

The combined probability function for gaussian time and amplitude distributions yields the expression for the noise rate as a function of threshold-to-noise ratio.

$$f_n = f_{n0} \cdot e^{-Q_T^2/2Q_n^2}$$

Of course, one can just as well use the corresponding voltage levels.

What is the noise rate at zero threshold f_{n0} ?

Since we are interested in the number of positive excursions exceeding the threshold, f_{n0} is $\frac{1}{2}$ the frequency of zero-crossings.

A rather lengthy analysis of the time dependence shows that the frequency of zero crossings at the output of an ideal band-pass filter with lower and upper cutoff frequencies f_1 and f_2 is

$$f_0 = 2 \sqrt{\frac{1}{3} \frac{f_2^3 - f_1^3}{f_2 - f_1}}$$

(Rice, Bell System Technical Journal, **23** (1944) 282 and **24** (1945) 46)

For a *CR-RC* filter with $\tau_i = \tau_d$ the ratio of cutoff frequencies of the noise bandwidth is

$$\frac{f_2}{f_1} = 4.5$$

so to a good approximation one can neglect the lower cutoff frequency and treat the shaper as a low-pass filter, *i.e.* $f_1 = 0$. Then

$$f_0 = \frac{2}{\sqrt{3}} f_2$$

An ideal bandpass filter has infinitely steep slopes, so the upper cutoff frequency f_2 must be replaced by the noise bandwidth.

The noise bandwidth of an *RC* low-pass filter with time constant τ is

$$\Delta f_n = \frac{1}{4\tau}$$

Setting $f_2 = \Delta f_n$ yields the frequency of zeros

$$f_0 = \frac{1}{2\sqrt{3}\tau}$$

and the frequency of noise hits vs. threshold

$$f_n = f_{n0} \cdot e^{-Q_{th}^2/2Q_n^2} = \frac{f_0}{2} \cdot e^{-Q_{th}^2/2Q_n^2} = \frac{1}{4\sqrt{3}\tau} \cdot e^{-Q_{th}^2/2Q_n^2}$$

Thus, the required threshold-to-noise ratio for a given frequency of noise hits f_n is

$$\frac{Q_T}{Q_n} = \sqrt{-2 \log(4\sqrt{3} f_n \tau)}$$

Note that the threshold-to-noise ratio determines the product of noise rate and shaping time, i.e. for a given threshold-to-noise ratio the noise rate is higher at short shaping times

- ⇒ The noise rate for a given threshold-to-noise ratio is proportional to bandwidth.
- ⇒ To obtain the same noise rate, a fast system requires a larger threshold-to-noise ratio than a slow system with the same noise level.

Frequently a threshold discriminator system is used in conjunction with other detectors that provide additional information, for example the time of a desired event.

In a collider detector the time of beam crossings is known, so the output of the discriminator is sampled at specific times.

The number of noise hits then depends on

1. the sampling frequency (e.g. bunch crossing frequency) f_S
2. the width of the sampling interval Δt , which is determined by the time resolution of the system.

The product $f_S \Delta t$ determines the fraction of time the system is open to recording noise hits, so the rate of recorded noise hits is $f_S \Delta t f_n$.

Often it is more interesting to know the probability of finding a noise hit in a given interval, i.e. the occupancy of noise hits, which can be compared to the occupancy of signal hits in the same interval.

This is the situation in a storage pipeline, where a specific time interval is read out after a certain delay time (e.g. trigger latency)

The occupancy of noise hits in a time interval Δt

$$P_n = \Delta t \cdot f_n = \frac{\Delta t}{2\sqrt{3}\tau} \cdot e^{-Q_T^2/2Q_n^2}$$

i.e. the occupancy falls exponentially with the square of the threshold-to-noise ratio.

The dependence of occupancy on threshold can be used to measure the noise level.

$$\log P_n = \log\left(\frac{\Delta t}{2\sqrt{3}\tau}\right) - \frac{1}{2}\left(\frac{Q_T}{Q_n}\right)^2$$

so the *slope* of $\log P_n$ vs. Q_T^2 yields the noise level, *independent of the details of the shaper*, which affect only the offset.

