

7.1 Overview

The mechanical elements and services of the pixel detector are described in this section. We also describe the integration of the major components of the pixel detector and installation in ATLAS. The pixel detector, including the internal services, is located within the pixel support tube (PST) as already shown in Figure 2.1. A perspective view of the pixel detector elements within the PST is shown in Figure 7.1.1.

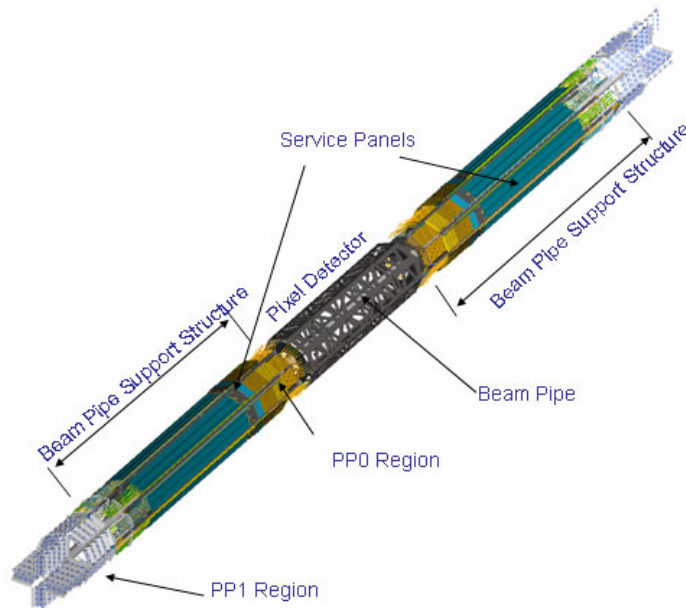

Figure 7.1.1 A perspective view of the pixel detector and internal services. **Placeholder******

The active regions of the pixel detector are divided into a barrel region and two identical endcaps. The active elements in the barrel region are staves (with integrated cooling) each supporting 13 modules. The staves are held precisely by half-shells that are joined to form the three barrel layers of the detector. The active elements in the endcap regions are disk sectors (also with integrated cooling) each supporting six modules. Eight disk sectors are supported on a disk support ring. There are three disks in each of the two endcaps. The design and construction of these barrel and endcap elements are described in subsequent sections of this chapter.

The barrel shells and the disk rings are rigidly supported by a support frame constructed in three sections – a barrel section and two identical endcap sections. The support frame is constructed from carbon composites apart from small aluminum blocks in the regions where the barrel and endcap frame sections are bolted together. A picture of the support frame is shown in Figure 7.1.2. Four pixel mounts are mounted on endplates attached to the support frame. These precision mounts engage mating supports in the PST when the support frame and the attached services slide through the PST during the installation procedure.



Figure 7.1.2 The pixel detector support frame. ****Placeholder****

The beryllium beam pipe [Ref] within the ATLAS detector is held on each side of the support frame by additional composite structures, the Beam Pipe Support Structure (BPSS). The BPSS also supports the Service Quarter Panels (SQP) that contain coolant pipes and all electrical services for the pixel modules [Section 6]. A low mass cable from each pixel module (Type 0 cable) is connected to the SQPs via small connectors at Patch Panel 0 (PP0 – see Figure 7.1.1). The connections to the external services for the pixel detector are made to the SQPs at Patch Panel 1 (PP1) that is at the end of the Pixel Support Tube.

A schematic overview of the pixel electrical and optical services is given in Figure 7.1.3.

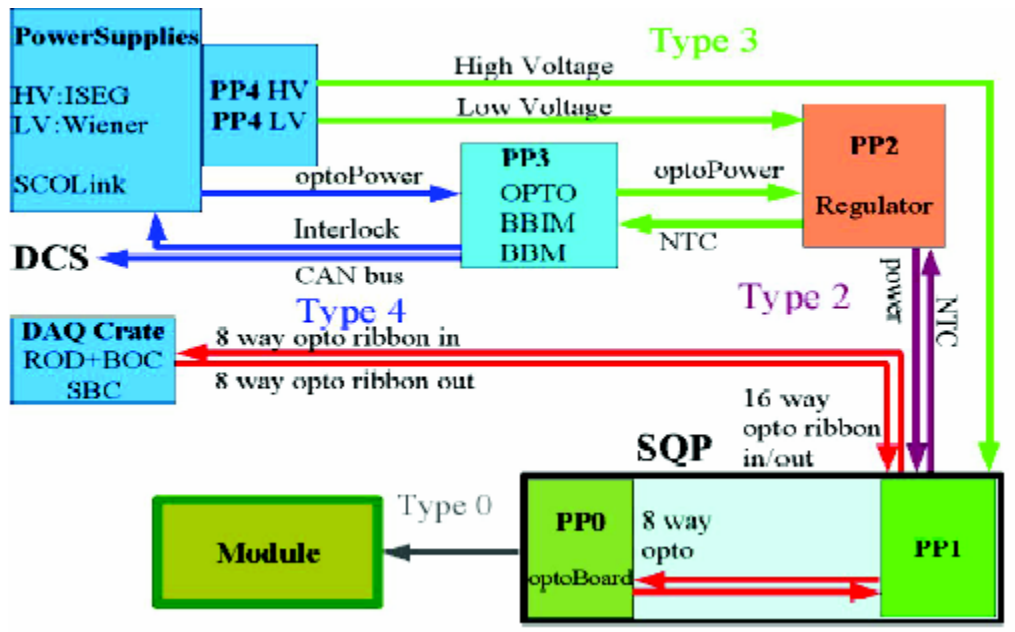

Figure 7.1.3 Schematic of the pixel electrical and optical services. ****Placeholder****

Optical transceivers (optoboards) are located on the SQPs (see 4.4 for a description of the optical system). Power for the pixel modules is supplied by power supplies located in the ATLAS services caverns [Ref] and is regulated at the Patch Panel 2 (PP2) location. High

voltage is supplied by power supplies in the service caverns. Routing of low voltages and high voltages occurs at the Patch Panel 4 (PP4) region. Monitoring (and power distribution for the optical items) occurs at the Patch Panel 3 (PP3) region.

Cooling connections are also made at PP0 and at PP1. Individual heat exchangers for each pixel cooling circuit are embedded in the Service Quarter Panels. The heater exchangers and these connections are described briefly below in section 7.4. A general description of the ATLAS evaporative cooling system may be found in [Ref].