

The Art and Science of Making a Major Technical Decision

Choosing the Technology for the International Linear Collider

Barry Barish
Caltech
RPM - LBNL
7-Oct-04

Why ITRP?

- Two parallel developments over the past few years (**the science & the technology**)
 - The precision information from LEP and other data have pointed to a low mass Higgs; Understanding electroweak symmetry breaking, whether supersymmetry or an alternative, will require precision measurements.
 - There are strong arguments for the complementarity between a ~0.5-1.0 TeV LC and the LHC science.
 - Designs and technology demonstrations have matured on two technical approaches for an e^+e^- collider that are well matched to our present understanding of the physics. (We note that a C-band option could have been adequate for a 500 GeV machine, if NLC/GLC and TESLA were not deemed mature designs).

Electroweak Precision Measurements

Winter 2003

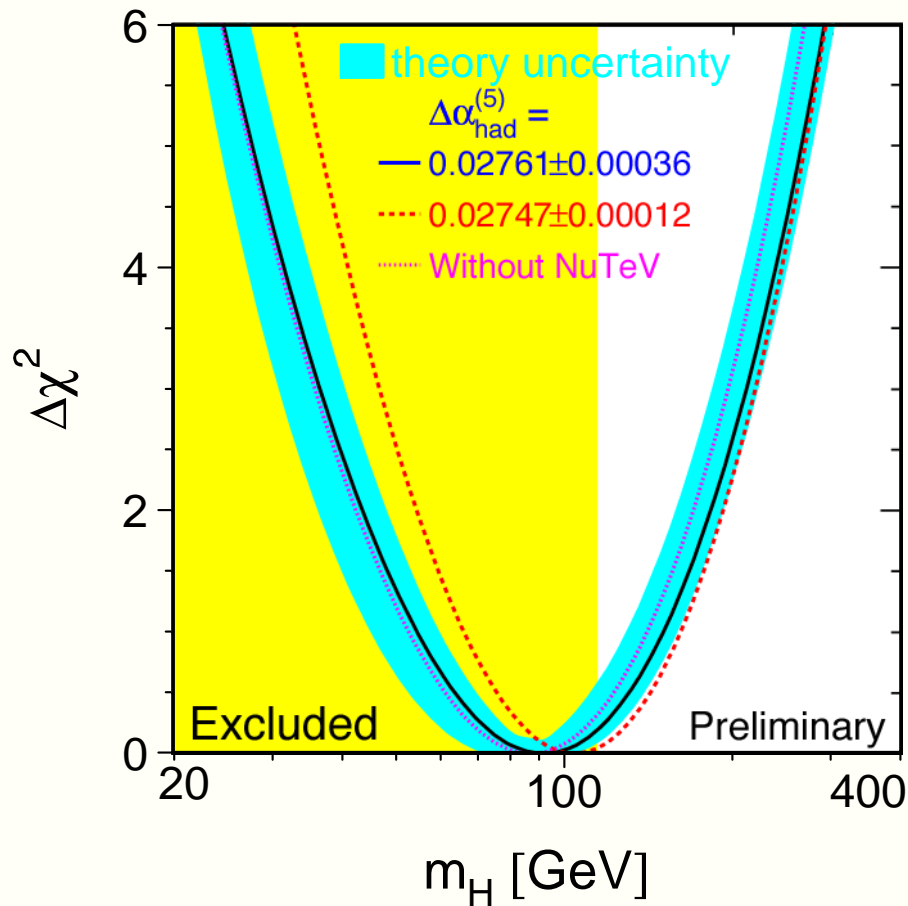

LEP results strongly point to a low mass Higgs and an energy scale for new physics < 1TeV

Why ITRP?

- Two parallel developments over the past few years (**the science & the technology**)
 - The precision information from LEP and other data have pointed to a low mass Higgs; Understanding electroweak symmetry breaking, whether supersymmetry or an alternative, will require precision measurements.
 - There are strong arguments for the complementarity between a ~0.5-1.0 TeV LC and the LHC science.
 - Designs and technology demonstrations have matured on two technical approaches for an e^+e^- collider that are well matched to our present understanding of the physics. (We note that a C-band option could have been adequate for a 500 GeV machine, if NLC/GLC and TESLA were not deemed mature designs).

LHC/LC Complementarity

The 500 GeV Linear Collider Spin Measurement

LHC should discover the Higgs

The linear collider will measure the spin of any Higgs it can produce.

The process $e^+e^- \rightarrow HZ$ can be used to measure the spin of a 120 GeV Higgs particle. The error bars are based on 20 fb^{-1} of luminosity at each point.

The Higgs must have spin zero

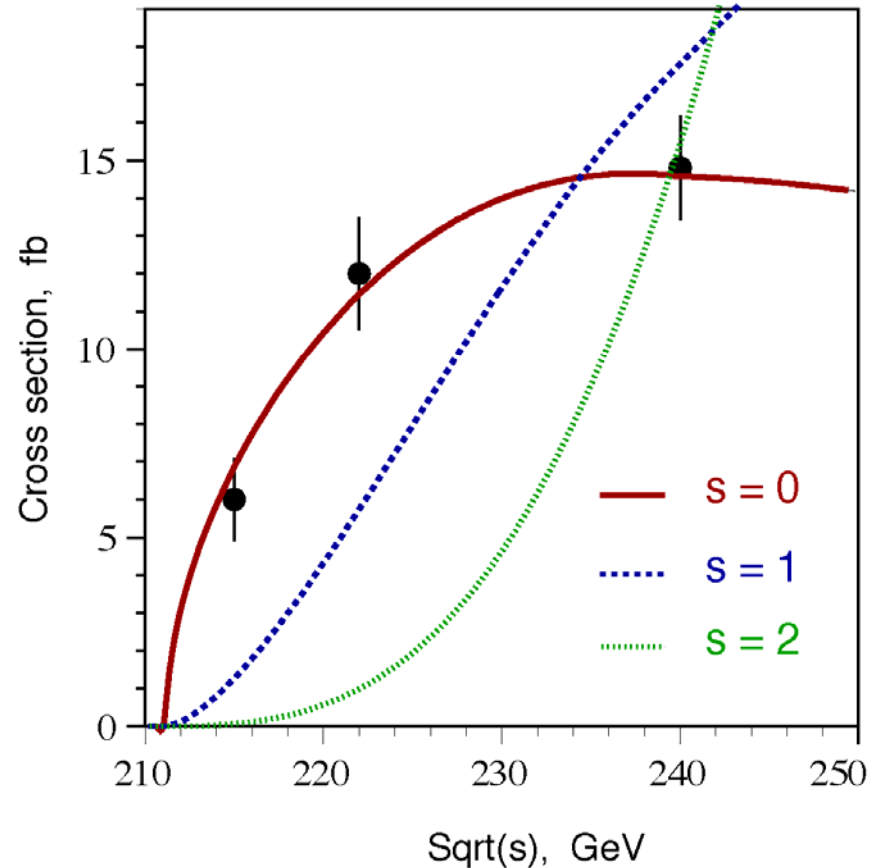

LHC/LC Complementarity

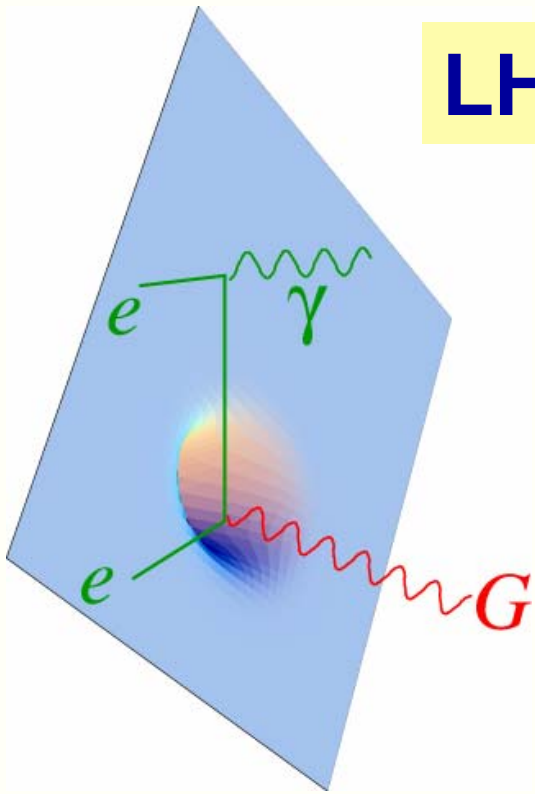

New space-time dimensions can be mapped by studying the emission of gravitons into the extra dimensions, together with a photon or jets emitted into the normal dimensions.

Extra Dimensions

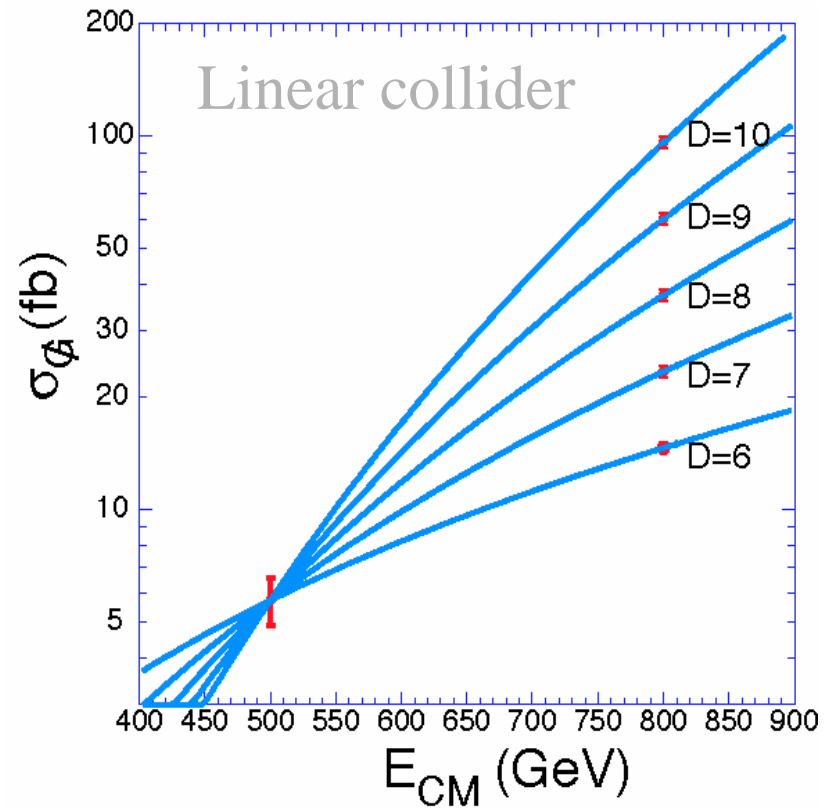

Why ITRP?

- Two parallel developments over the past few years (**the science & the technology**)
 - The precision information from LEP and other data have pointed to a low mass Higgs; Understanding electroweak symmetry breaking, whether supersymmetry or an alternative, will require precision measurements.
 - There are strong arguments for the complementarity between a $\sim 0.5\text{-}1.0$ TeV LC and the LHC science.
 - Designs and technology demonstrations have matured on two technical approaches for an e^+e^- collider that are well matched to our present understanding of the physics. (We note that a C-band option could have been adequate for a 500 GeV machine, if NLC/GLC and TESLA were not deemed mature designs).

What has the Accelerator R&D Produced?

INTERNATIONAL LINEAR COLLIDER

TECHNICAL REVIEW COMMITTEE

SECOND REPORT

2003

**The Report Validates the Readiness
of L-band and X-band Concepts**

TESLA Concept

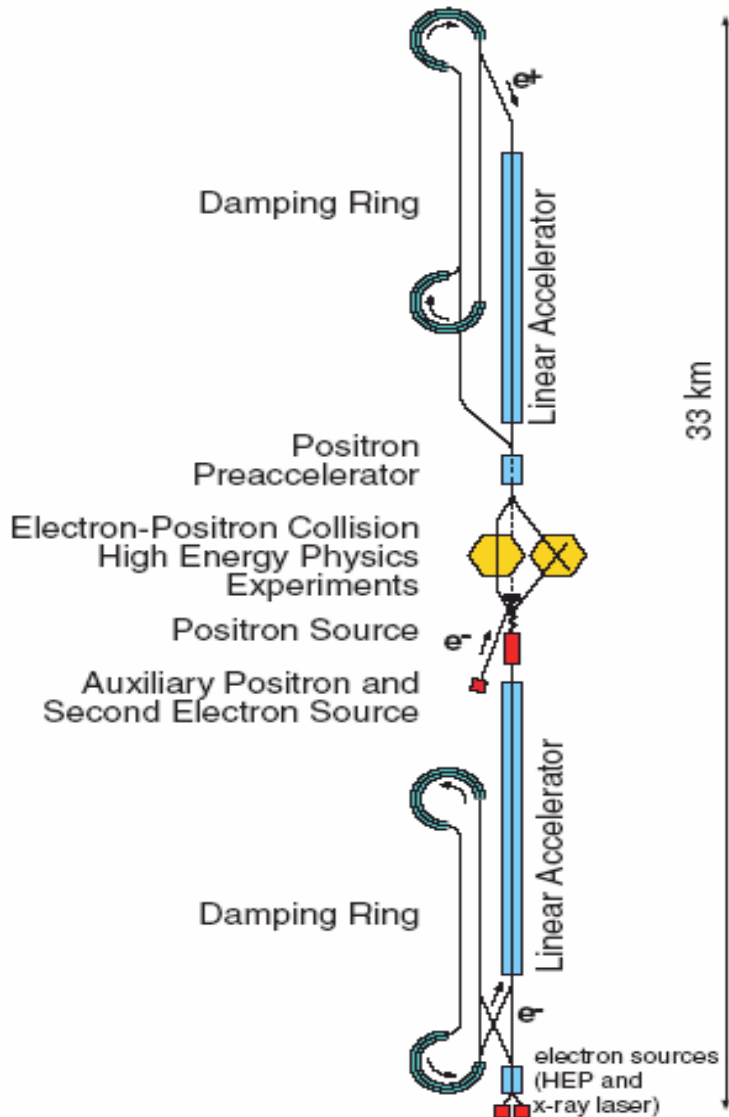

FIGURE 1. TESLA layout

- The main linacs are based on 1.3 GHz superconducting technology operating at 2 K. The cryoplant, of a size comparable to that of the LHC, consists of seven subsystems strung along the machines every 5 km.

TESLA Cavity

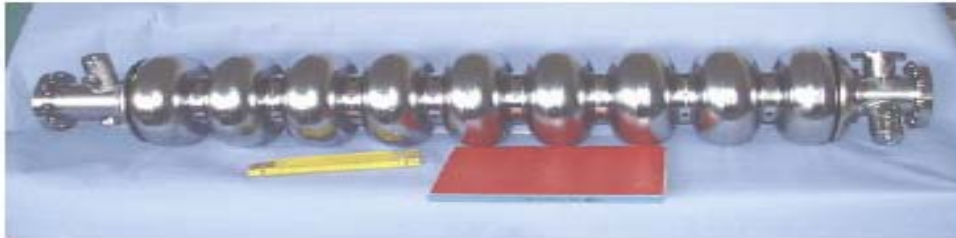

FIGURE 3. The 9-cell niobium cavity for TESLA

- **RF accelerator structures consist of close to 21,000 9-cell niobium cavities operating at gradients of 23.8 MV/m (unloaded as well as beam loaded) for 500 GeV c.m. operation.**
- **The rf pulse length is 1370 μ s and the repetition rate is 5 Hz. At a later stage, the machine energy may be upgraded to 800 GeV c.m. by raising the gradient to 35 MV/m.**

TESLA Single Tunnel Layout

- The TESLA cavities are supplied with rf power in groups of 36 by 572 10 MW klystrons and modulators.

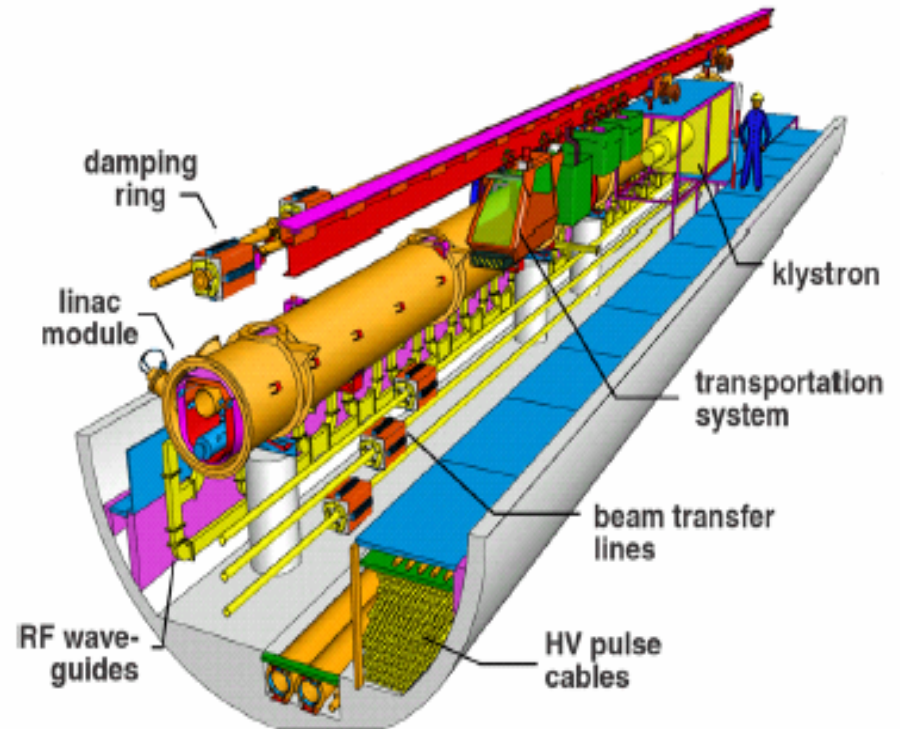
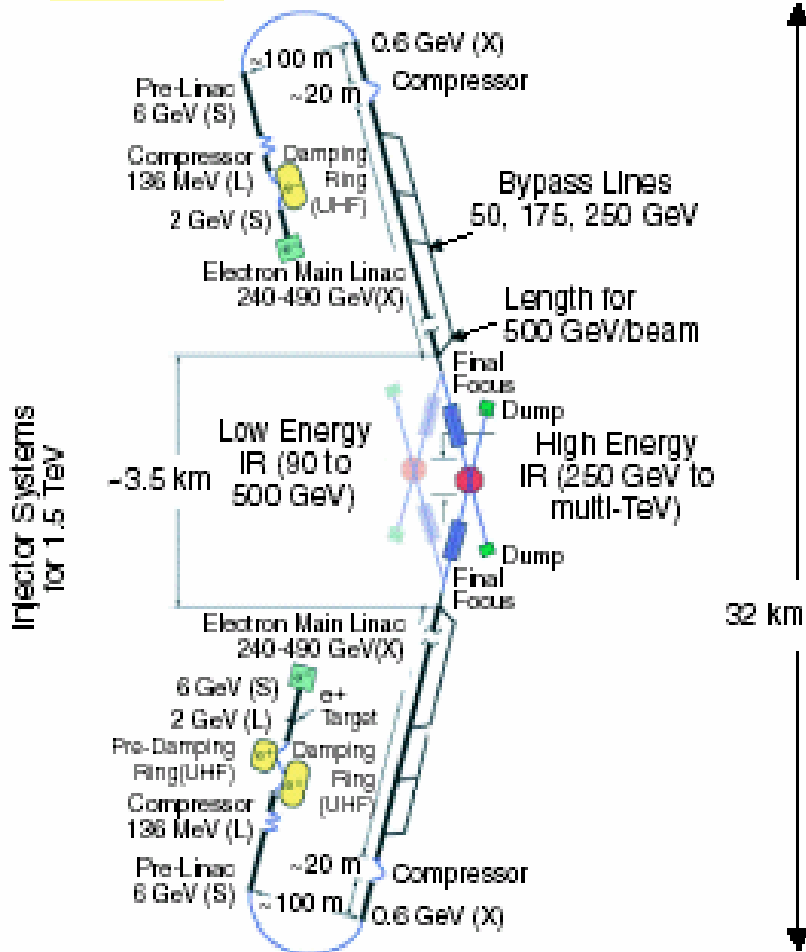

FIGURE 2. Sketch of the 5 m diameter TESLA linac tunnel

GLC/NLC Concept

GLC



- The JLC-X and NLC are essentially a unified single design with common parameters
- The main linacs are based on 11.4 GHz, room temperature copper technology.
- The main linacs operate at an unloaded gradient of 65 MV/m, beam-loaded to 50 MV/m.
- The rf systems for 500 GeV c.m. consist of 4064 75 MW Periodic Permanent Magnet (PPM) klystrons arranged in groups of 8, followed by 2032 SLED-II rf pulse compression systems

GLC / NLC Concept

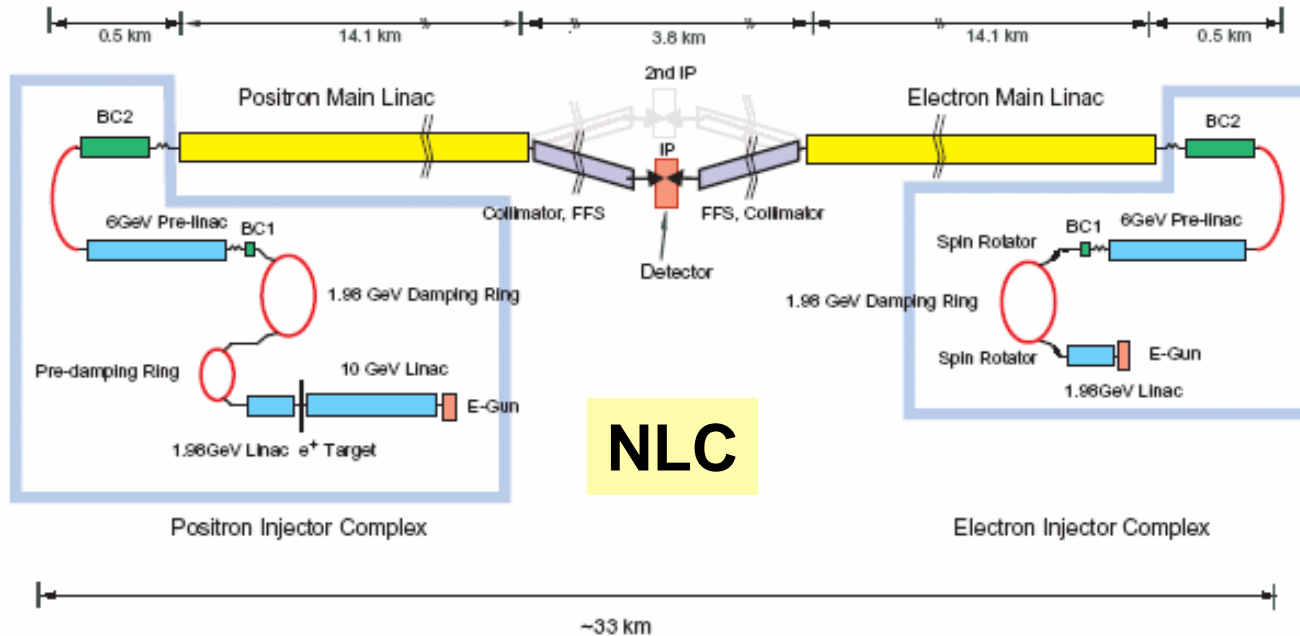

- The rf systems and accelerator structures are located in two parallel tunnels for each linac.
- For 500 GeV c.m. energy, these rf systems and accelerator structures are only installed in the first 7 km of each linac.
- The upgrade to 1 TeV is obtained by filling the rest of each linac, for a total two-linac length of 28 km.

JLC – C Band

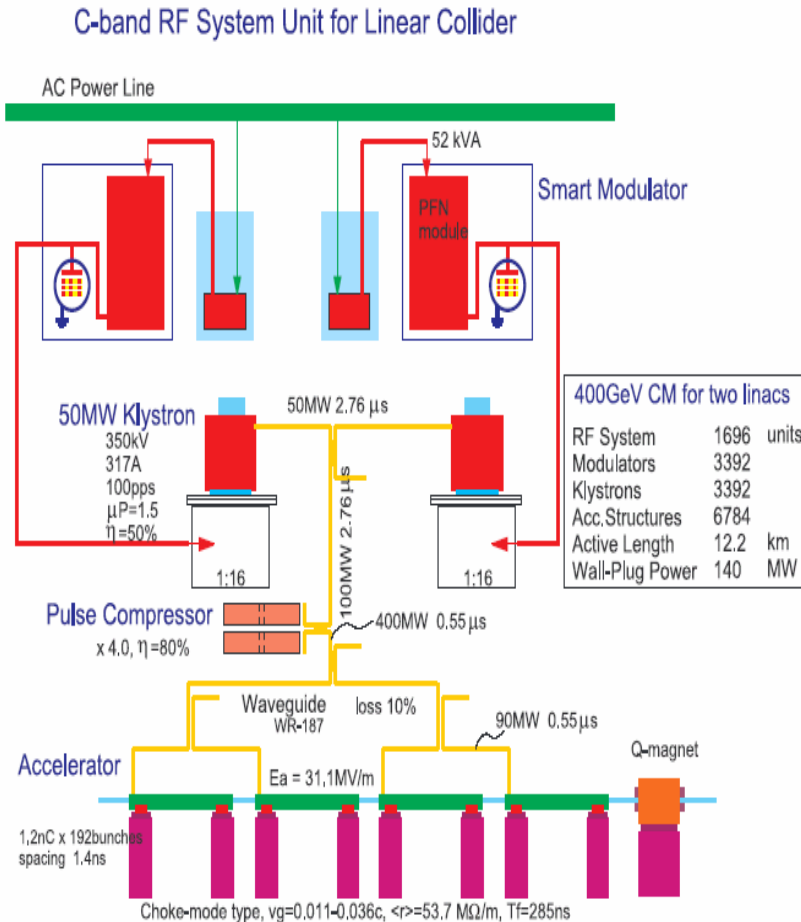

- The JLC-C is limited to an rf design using main linacs running at 5.7 GHz up to 400–500 GeV c.m.
- The unloaded gradient is about 42 MV/m and the beam-loaded gradient is about 32 MV/m, resulting in a two-linac length at 5.7 GHz of 17 km for a 400 GeV c.m. energy.

FIGURE 4. Schematic of a JLC-C linac rf unit (one of 848 per linac)

CLIC

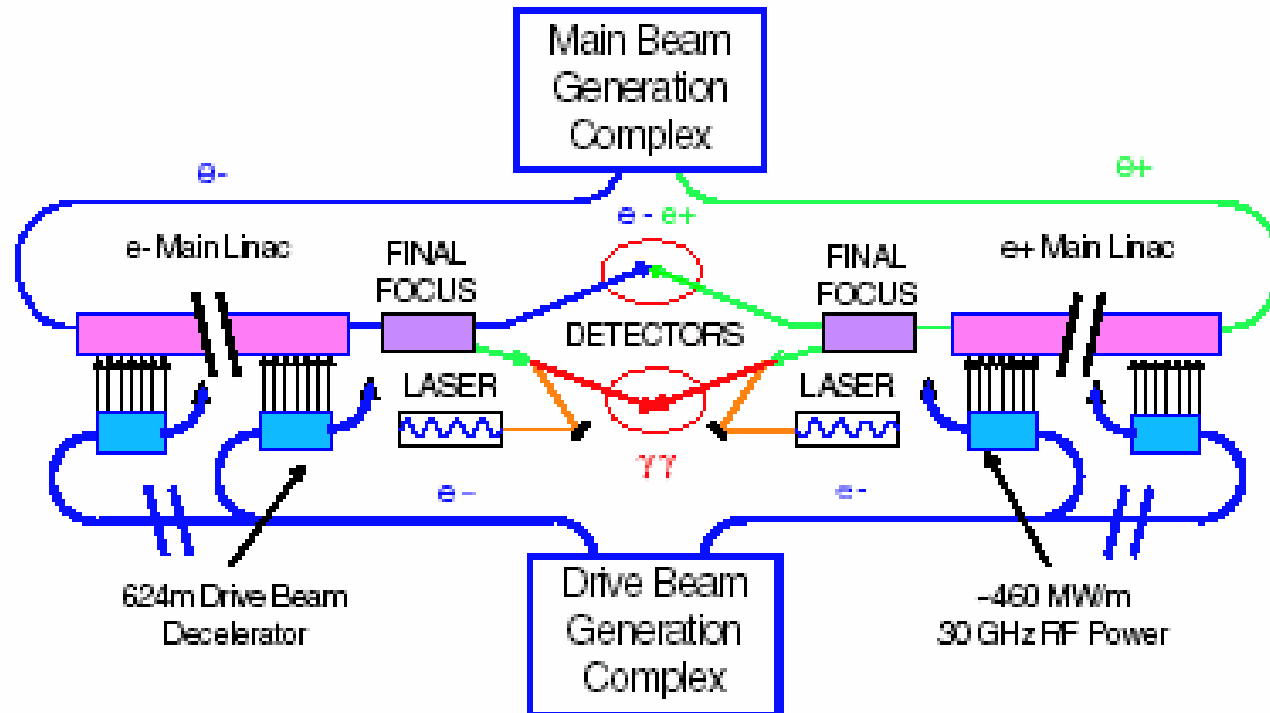

Why Decide Technology Now?

- **We have an embarrassment of riches !!!!**
 - Two alternate designs -- “warm” and “cold” have come to the stage where the show stoppers have been eliminated and the concepts are well understood.
 - R & D is very expensive (especially D) and to move to the “next step” (being ready to construct such a machine within about 5 years) will require more money and a concentration of resources, organization and a worldwide effort.
 - A major step toward a decision to construct a new machine will be enabled by uniting behind one technology, followed by a making a final global design based on the recommended technology.
 - **The final construction decision in ~5 years will be able to fully take into account early LHC and other physics developments.**



Parameters for the Linear Collider

September 30, 2003

Preamble to the List of Parameters

Over the past decade, studies in Asia, Europe and North America have described the scientific case for a future electron-positron linear collider [1,2,3,4]. A world-wide consensus has formed for a baseline LC project with centre-of-mass energies up to 500 GeV and with luminosity above $10^{34} \text{ cm}^{-2}\text{s}^{-1}$ [5].

Beyond this firm baseline machine, several upgrades and options are envisaged whose weight, priority and realization will depend upon the results obtained at the LHC and the baseline LC.

This document, prepared by the Parameters Subcommittee of the International Linear Collider Steering Committee, provides a set of parameters for the future Linear Collider and the corresponding values needed to achieve the anticipated physics program.

The ITRP Members

Jean-Eudes Augustin (FRANCE)

Jonathan Bagger (USA)

Barry Barish (USA) - Chair

Giorgio Bellettini (ITALY)

Paul Grannis (USA)

Norbert Holtkamp (USA)

George Kalmus (UK)

Gyung-Su Lee (KOREA)

Akira Masaike (JAPAN)

Katsunobu Oide (JAPAN)

Volker Soergel (Germany)

Hiroataka Sugawara (JAPAN)

David Plane - Scientific Secretary

ITRP Schedule of Events

- **Six Meetings**

- RAL (Jan 27,28 2004)



Tutorial & Planning

- DESY (April 5,6 2004)

- SLAC (April 26,27 2004)

- KEK (May 25,26 2004)

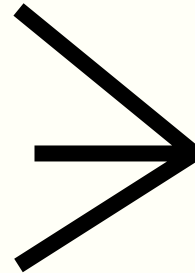

Site Visits

- Caltech (June 28,29,30 2004)



Deliberations

- Korea (August 11,12,13)



Recommendation

- ILCSC / ICFA (Aug 19)



Exec. Summary

- ILCSC (Sept 20)



Final Report

Arriving in Korea

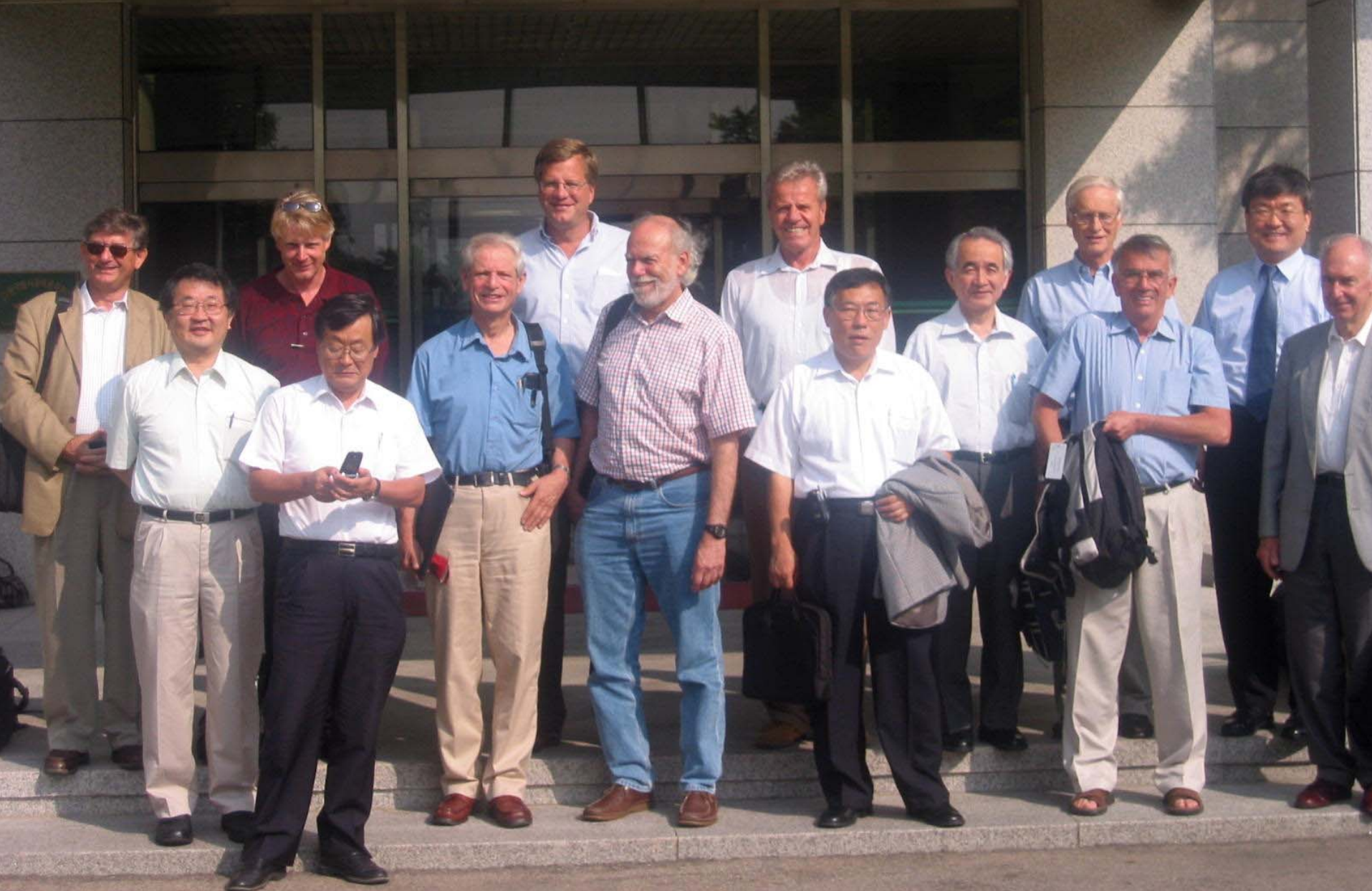

Deliberating in Korea



ITRP in Korea



*International Technology Recommendation Panel Meeting
August 11 ~ 13, 2004. Republic of Korea*

Our Process

- **We studied and evaluated a large amount of available materials**
- **We made site visits to DESY, KEK and SLAC to listen to presentations on the competing technologies and to see the test facilities first-hand.**
- **We have also heard presentations on both C-band and CLIC technologies**
- **We interacted with the community at LC workshops, individually and through various communications we received**
- **We developed a set of evaluation criteria (a matrix) and had each proponent answer a related set of questions to facilitate our evaluations.**
- **We assigned lots of internal homework to help guide our discussions and evaluations**

What that Entailed

- We each traveled at least 75,000 miles
- We read approximately 3000 pages
- We had constant interactions with the community and with each other
- We gave up a good part of our “normal day jobs” for six months
- We had almost 100% attendance by all members at all meetings
- We worked incredibly hard to “turn over every rock” we could find.

from Norbert Holtkamp

The Charge to the International Technology Recommendation Panel

General Considerations

The International Technology Recommendation Panel (the Panel) should recommend a Linear Collider (LC) technology to the International Linear Collider Steering Committee (ILCSC).

On the assumption that a linear collider construction commences before 2010 and given the assessment by the ITRC that both TESLA and ILC-X/NLC have rather mature conceptual designs, the choice should be between these two designs. If necessary, a solution incorporating C-band technology should be evaluated.

Note -- We have interpreted our charge as being to recommend a technology, rather than choose a design

Evaluating the Criteria Matrix

- **We analyzed the technology choice through studying a matrix having six general categories with specific items under each:**
 - the scope and parameters specified by the ILCSC;
 - technical issues;
 - cost issues;
 - schedule issues;
 - physics operation issues;
 - and more general considerations that reflect the impact of the LC on science, technology and society
- **We evaluated each of these categories with the help of answers to our “questions to the proponents,” internal assignments and reviews, plus our own discussions**

Evaluation: Scope and Parameters

- **The Parameters Document describes a machine with physics operation between 200 and 500 GeV.**
 - **The luminosity of this machine must be sufficient to acquire 500 fb⁻¹ of luminosity in four years of running, after an initial year of commissioning.**
 - **The baseline machine must be such that its energy can be upgraded to approximately 1 TeV, as required by physics.**
 - **The upgraded machine should have luminosity sufficient to acquire 1 ab⁻¹ in an additional three or four years of running.**
- **The ITRP evaluated each technology in the light of these requirements, which reflect the science goals of the machine. It examined technical, cost, schedule and operational issues.**

Evaluation: Scope and Parameters

- **The Panel's general conclusion was that each technology would be capable, in time, of achieving the goals set forth in the Parameters Document.**
- **The Panel felt that the energy goals could be met by either technology.**
 - **The higher accelerating gradient of the warm technology would allow for a shorter main linac.**
- **The luminosity goals were deemed to be aggressive, with technical and schedule risk in each case.**
 - **On balance, the Panel judged the cold technology to be better able to provide stable beam conditions, and therefore more likely to achieve the necessary luminosity in a timely manner.**

Evaluation: Technical Issues

- The Panel was gratified to see the C-band progress
 - The C-band technology was originally conceived as an alternative to X-band for acceleration up to 500 GeV.
 - The technology is feasible and can be readily transferred to industry, with applications in science (XFELs) and industry (e.g. medical accelerators).

Spring-8 Compact SASE Source

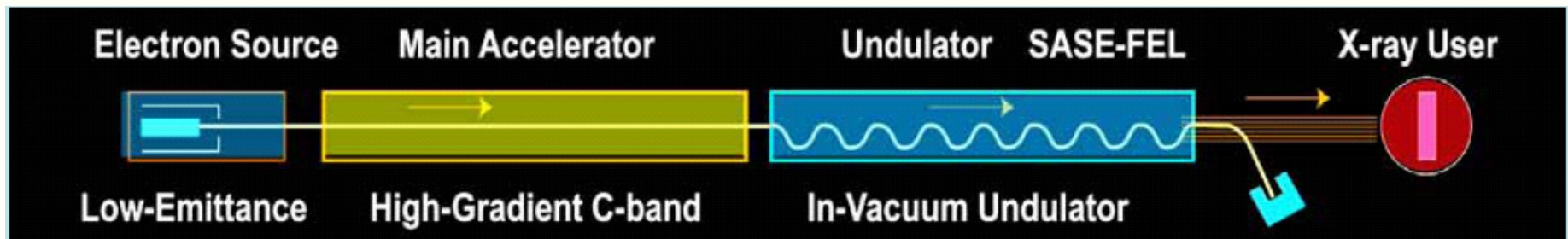

Low Emittance Injector → High Gradient Accelerator → Short Period Undulator

Evaluation: Technical Issues

- **Compact Linear Collider Study (CLIC)**

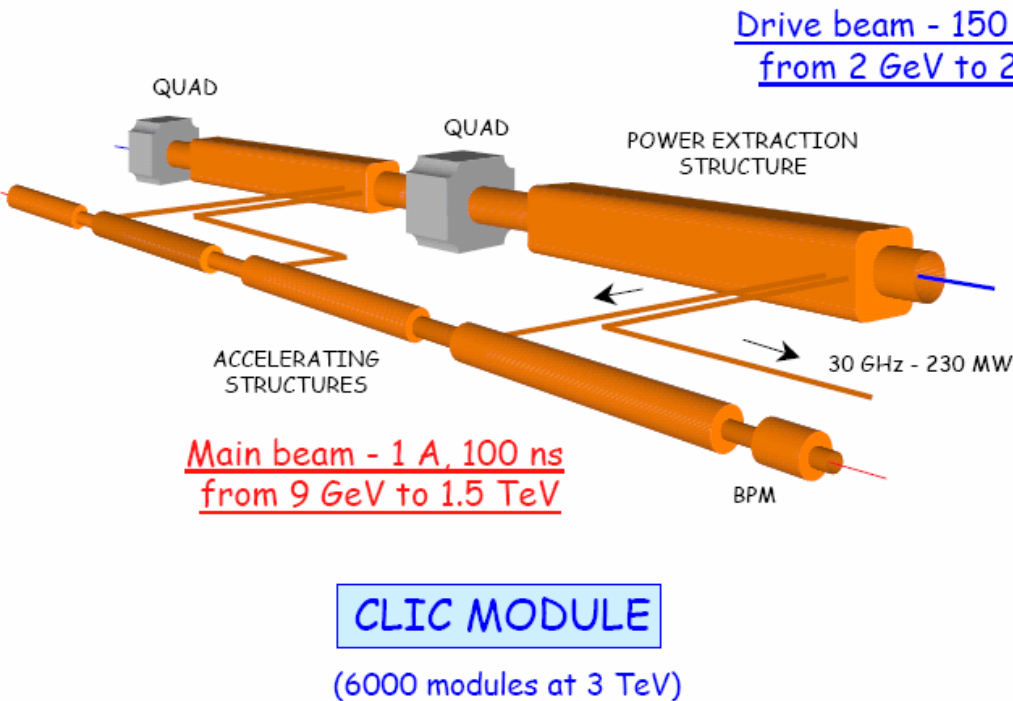

The main linac rf power is produced by decelerating a high-current (150 A) low-energy (2.1 GeV) drive beam

In the short (300 m), low-frequency drive beam accelerator, a long beam pulse is efficiently accelerated in fully loaded structures.

- The Panel was impressed with the state of CLIC R&D.
 - CLIC will face many challenges to demonstrate the feasibility of high-current beam-derived rf generation.
 - A vigorous effort to attack these issues at CTF3 at CERN.

Evaluation: Technical Issues

- The Panel evaluated the main linacs and subsystems for X-band and L-band to identify performance-limiting factors for construction and commissioning.
 - In general, the Panel found the LC R&D to be far advanced. The global R&D effort uncovered a variety of issues that were mitigated through updated designs.

Evolution of RF Unit Scheme

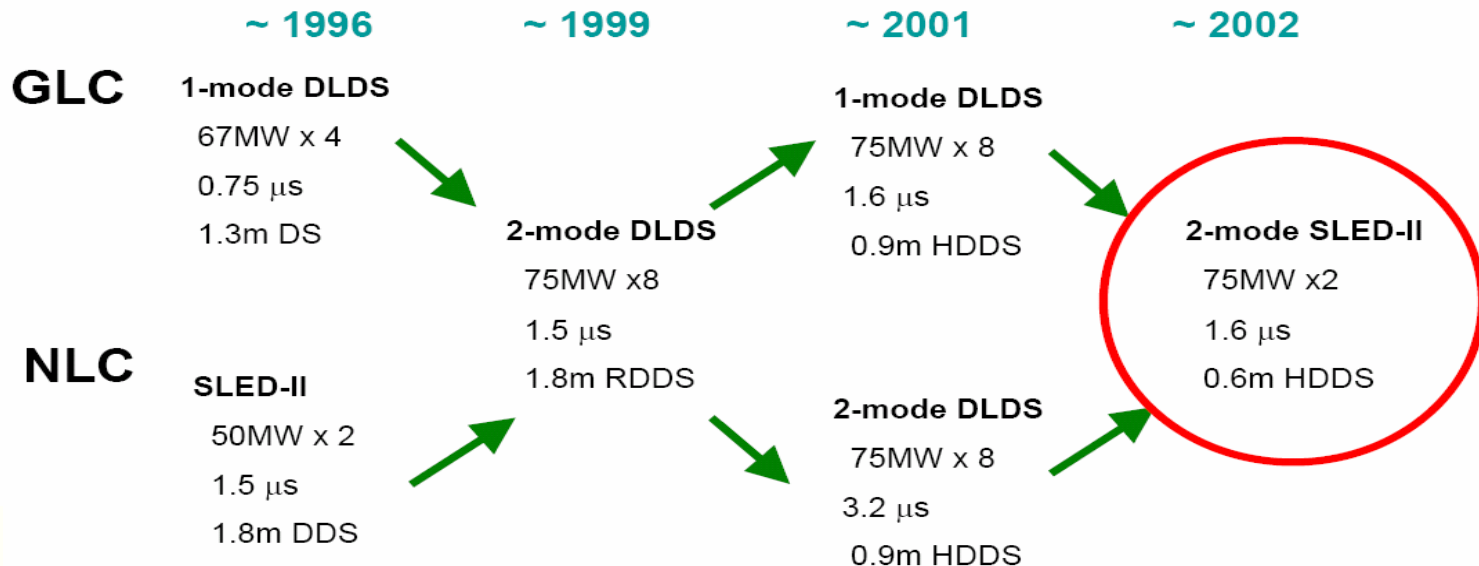

Evaluation: Technical Issues

- **For the warm technology, major subsystems were built to study actual performance.**
 - **The KEK damping ring was constructed to demonstrate the generation and damping of a high-intensity bunch train at the required emittance, together with its extraction with sufficient stability.**

Experimental Test Facility - KEK

- Prototype Damping Ring for X-band Linear Collider
- Development of Beam Instrumentation and Control



	<i>ATF</i>	<i>GLC/NLC-DR</i>	
E_b	1.28 (1.54 max)	1.98	GeV
N_e	$\sim 10^{10}$	$0.75 \cdot 10^{10}$	e-/bunch
S_b	2.8	1.4	ns
N_b	20	192	/pulse
$\gamma\varepsilon_x$	~ 4	3	$\mu\text{m}\cdot\text{rad}$
$\gamma\varepsilon_y$	~ 0.015	0.02	$\mu\text{m}\cdot\text{rad}$

Evaluation: Technical Issues

- **For the warm technology, major subsystems were built to study actual performance.**
 - **The KEK damping ring was constructed to demonstrate the generation and damping of a high-intensity bunch train at the required emittance, together with its extraction with sufficient stability.**
 - **The Final Focus Test Beam at SLAC was constructed to demonstrate demagnification of a beam accelerated in the linac.**

Evaluation: Technical Issues

Final Focus Test Beam Collaboration

BINP (Novosibirsk)

DESY

Fermilab

IBM

Kawasaki

KEK

LAL (Orsay)

MPI(Munich)

Rochester

SLAC

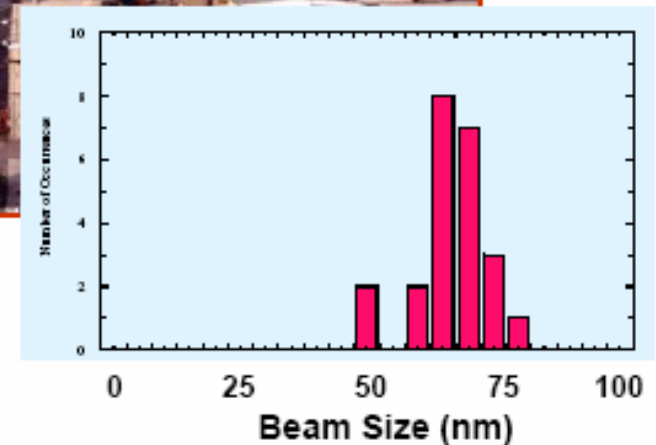

**Vertical beam size of 60-70 nm
... the needed demagnification.**

Evaluation: Technical Issues

- **For the warm technology, major subsystems were built to study actual performance.**
 - **The KEK damping ring was constructed to demonstrate the generation and damping of a high-intensity bunch train at the required emittance, together with its extraction with sufficient stability.**
 - **The Final Focus Test Beam at SLAC was constructed to demonstrate demagnification of a beam accelerated in the linac.**
 - **As a result, the subsystem designs are more advanced for the warm technology.**

Evaluation: Technical Issues

- In general, the cold technology carries higher risk in the accelerator subsystems other than the linacs, while the warm technology has higher risk in the main linacs and their individual components.
- The accelerating structures have risks that were deemed to be comparable in the two technologies.
 - The warm X-band structures require demonstration of their ability to run safely at high gradients for long periods of time.
 - The cold superconducting cryomodules need to show that they can manage field emission at high gradients.
- For the cold, industrialization of the main linac components and rf systems is now well advanced.

Evaluation: Technical Issues

- **Superconducting RF Linac Concept demonstrated in TESLA Test Facility**

TESLA Test Facility Linac

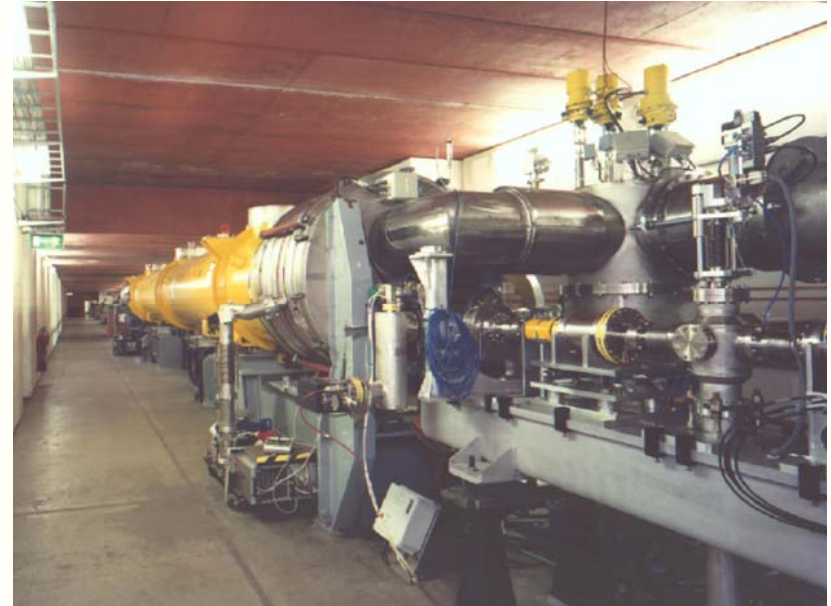
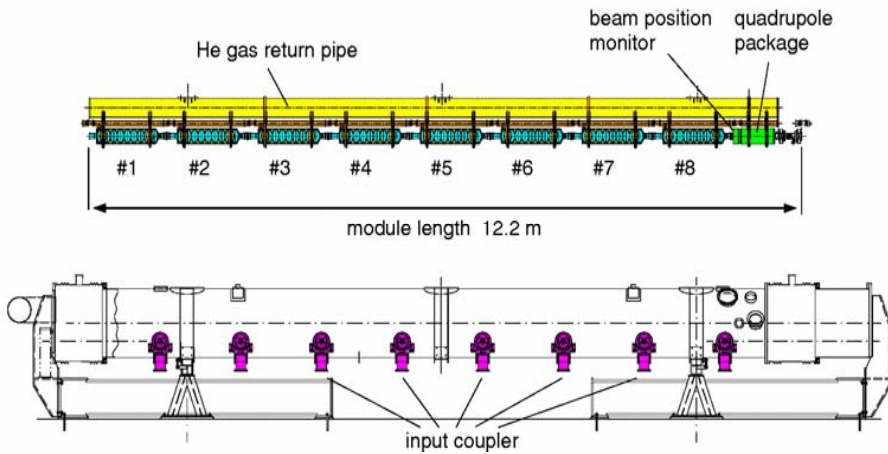
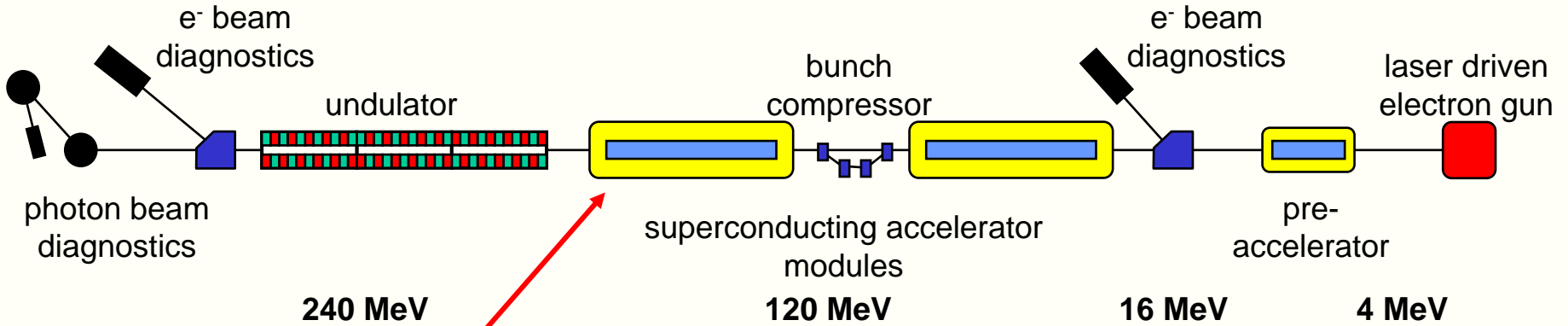

Evaluation: Technical Issues

- **Superconducting RF Linac Concept demonstrated in TESLA Test Facility**
- **Many cold technology components will be tested over the coming few years in a reasonably large-scale prototype through construction of the superconducting XFEL at DESY.**

Evaluation: Technical Issues

- **Superconducting RF Linac Concept demonstrated in TESLA Test Facility**
- **Many cold technology components will be tested over the coming few years in a reasonably large-scale prototype through construction of the superconducting XFEL at DESY.**
- **A superconducting linac has high intrinsic efficiency for beam acceleration, which leads to lower power consumption.**

Site power: **140 MW**

Power Usage TESLA Design

Linac: 97MW

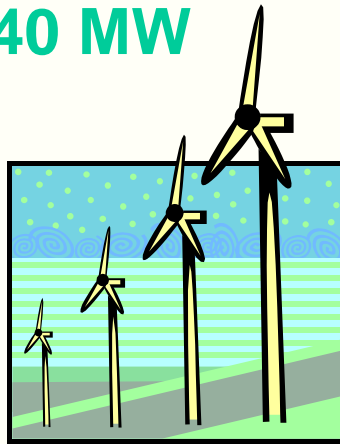

Sub-systems: 43MW

RF:
76MW



78%

Cryogenics:
21MW

Injectors

Damping rings

Water,
ventilation, ...

Beam:
22.6MW



65%



60%

Evaluation: Technical Issues

- **The lower accelerating gradient in the superconducting cavities implies that the length of the main linac in a cold machine is greater than it would be in a warm machine of the same energy.**
- **Future R&D must stress ways to extend the energy reach to 1 TeV, and even somewhat beyond.**

Electro-polishing

(Improve surface quality -- pioneering work done at KEK)

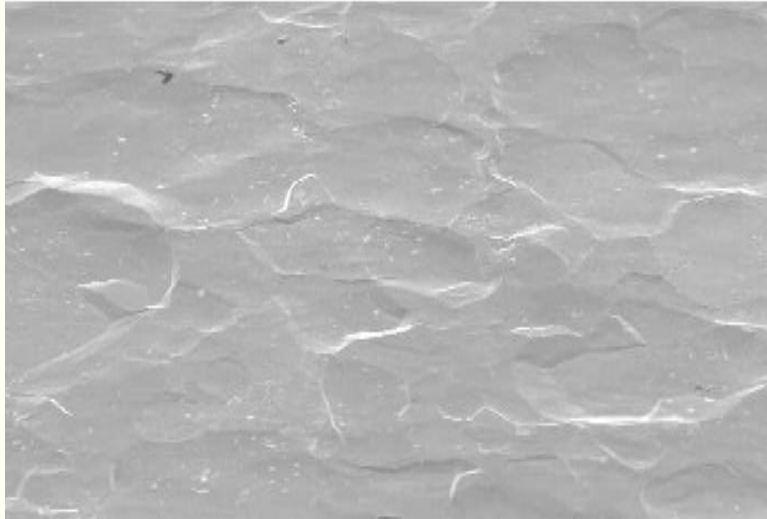

BCP



EP

- **Several single cell cavities at $g > 40$ MV/m**
- **4 nine-cell cavities at ~ 35 MV/m, one at 40 MV/m**
- **Theoretical Limit 50 MV/m**

New Cavity Shape for Higher Gradient?

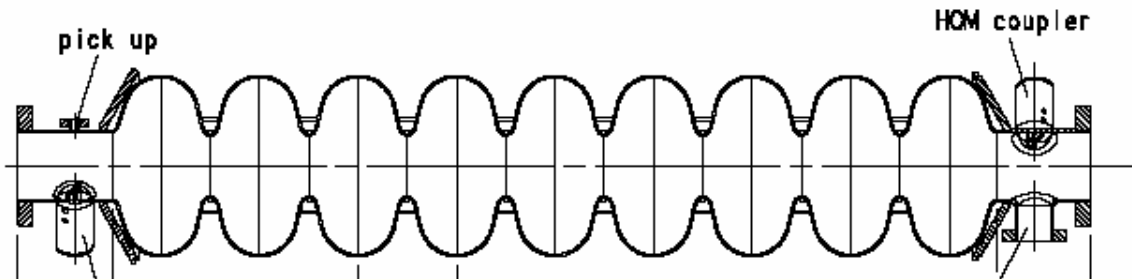

TESLA Cavity

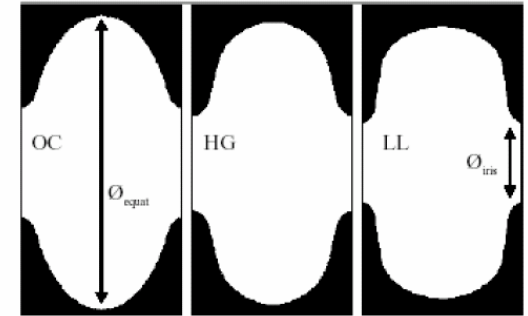

Alternate Shapes

- A new cavity shape with a small H_p/E_{acc} ratio around $35\text{Oe}/(\text{MV}/\text{m})$ must be designed.
 - H_p is a surface peak magnetic field and E_{acc} is the electric field gradient on the beam axis.
 - For such a low field ratio, the volume occupied by magnetic field in the cell must be increased and the magnetic density must be reduced.
 - This generally means a smaller bore radius.
 - There are trade-offs (eg. Electropolishing, weak cell-to-cell coupling, etc)

Evaluation: Technical Issues

- In a superconducting rf structure, the rf pulse length, the length of the bunch train, and interbunch time interval are all large. This offers many advantages.
- The disadvantages are mainly related to the complex and very long damping rings, and the large heat load on the production target for a conventional positron source, which might require a novel source design.
 - Storage rings are among the best-understood accelerator subsystems today, and much of this knowledge can be transferred to the linear collider damping rings.
 - Beam dynamics issues such as instabilities, ion effects, and intrabeam scattering have been well studied in those machines.

Evaluation: Technical Issues

- **Achieving design luminosity will be a critical measure of the collider's success. A number of arguments indicate it will be easier with the cold technology.**
 - **The cold technology permits greater tolerance to beam misalignments and other wakefield-related effects.**
 - **Natural advantage in emittance preservation because the wakefields are orders of magnitude smaller**
 - **The long bunch spacing eliminates multi-bunch effects and eases the application of feedback systems.**
 - **This feedback will facilitate the alignment of the nanometer beams at the collision point.**
- **For these reasons, we deem the cold machine to be more robust, even considering the inaccessibility of accelerating components within the cryogenic system.**

Evaluation: Cost Issues

- **The Panel spent considerable effort gathering and analyzing all information that is available regarding the total costs and the relative costs of the two options.**
- **At the present conceptual and pre-industrialized stage of the linear collider project, uncertainties in estimating the total costs are necessarily large.**
- **Although it might be thought that relative costing could be done with more certainty, there are additional complications in determining even the relative costs of the warm and cold technologies because of differences in design choices and differences in costing methods used in different regions.**

Evaluation: Cost Issues

- **Some of the important contributors to the uncertainties are:**
 - **Design and implementation plans for important technological components of each machine are in a preliminary state.**
 - **Differences in design philosophy by the proponents lead to differences in construction cost, as well as final performance. These cannot be resolved until a global and integrated design exists.**
 - **Assumptions about industrialization/learning curves for some key components have large uncertainties at this early stage in the design.**
 - **Present cost estimates have some regional philosophies or prejudices regarding how the project will be industrialized. Contingency accounting, management overheads, staff costs for construction and R&D costs for components are all treated differently; this adds uncertainty to cost comparisons.**

Evaluation: Cost Issues

- **Some of the important contributors to the uncertainties are: (continued)**
 - **In an international project, the procurement of substantial parts of the collider will be from outside the regions that prepared the present estimates, and this can considerably alter the costs.**
 - **The costs of operating the accelerator are also difficult to determine at this stage without a better definition of the reliability, access and staffing requirements, as well as the cost of power and component replacement.**
- **As a result of these considerations, the Panel concluded that comparable warm and cold machines, in terms of energy and luminosity, have total construction and lifetime operations costs that are within the present margin of errors of each other.**

Evaluation: Schedule Issues

- In accordance with our charge, we assumed that LC construction would start before 2010, and that it would be preceded by a coordinated, globally collaborative effort of research, development, and engineering design.
- Based on our assessment of the technical readiness of both designs, we concluded that the technology choice will not significantly affect the likelihood of meeting the construction start milestone.
- We believe that the issues that will drive the schedule are primarily of a non-technical nature.

Evaluation: Physics Operations Issues

- **Several factors favor the cold machine:**
 - The long separation between bunches in a cold machine allows full integration of detector signals after each bunch crossing. In a warm machine, the pileup of energy from multiple bunch crossings is a potential problem, particularly in forward directions.
 - The energy spread is somewhat smaller for the cold machine, which leads to better precision for measuring particle masses.
 - If desired, in a cold machine the beams can be collided head-on in one of the interaction regions. Zero crossing angle might simplify shielding from background.
 - a nonzero crossing angle permits the measurement of beam properties before and after the collision, giving added constraints on the determination of energy and polarization at the crossing point.

Evaluation: General Considerations

- **Linear collider R&D affects other scientific areas**
 - the development of high-gradient superconducting cavities is a breakthrough that will find applications in light sources and X-ray free electron lasers, as well as in accelerators for intense neutrino sources, nuclear physics, and materials science.
 - New light sources and XFELs will open new opportunities in biology and material sciences.
 - The superconducting XFEL to be constructed at DESY is a direct spin-off from linear collider R&D.
 - the R&D work done for the X-band rf technology is of great interest for accelerators used as radiation sources in medical applications, as well as for radar sources used in aircraft, ships and satellites, and other applications.

The Recommendation

- **We recommend that the linear collider be based on superconducting rf technology**

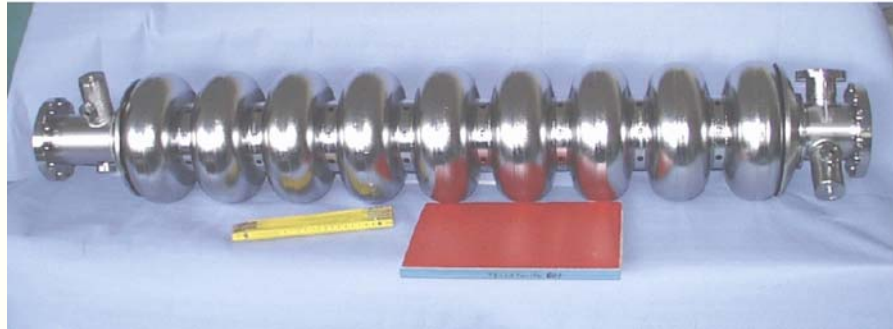

- This recommendation is made with the understanding that we are recommending a technology, not a design. We expect the final design to be developed by a team drawn from the combined warm and cold linear collider communities, taking full advantage of the experience and expertise of both (from the Executive Summary).
- The superconducting technology has several very nice features for application to a linear collider. They follow in part from the low rf frequency.

Some of the Features of SC Technology

- **The large cavity aperture and long bunch interval reduce the complexity of operations, reduce the sensitivity to ground motion, permit inter-bunch feedback and may enable increased beam current.**
- **The main linac rf systems, the single largest technical cost elements, are of comparatively lower risk.**

TESLA Cost estimate 500GeV LC, one e+e- IP

3,136 M€ (no contingency, year 2000) + ~7000 person years

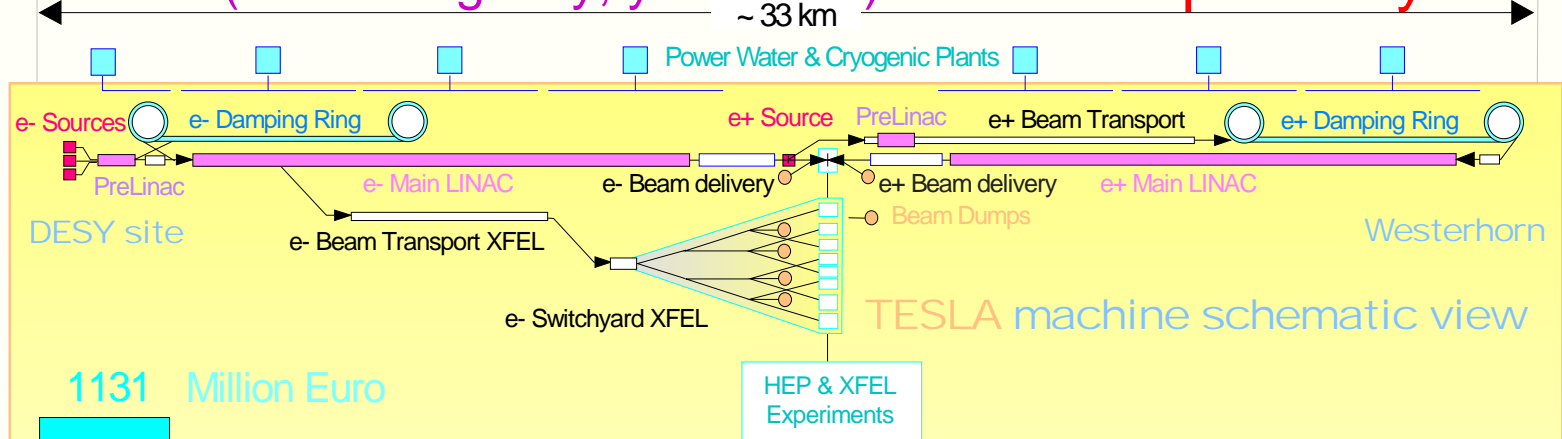

1131 Million Euro

Machine cost distribution

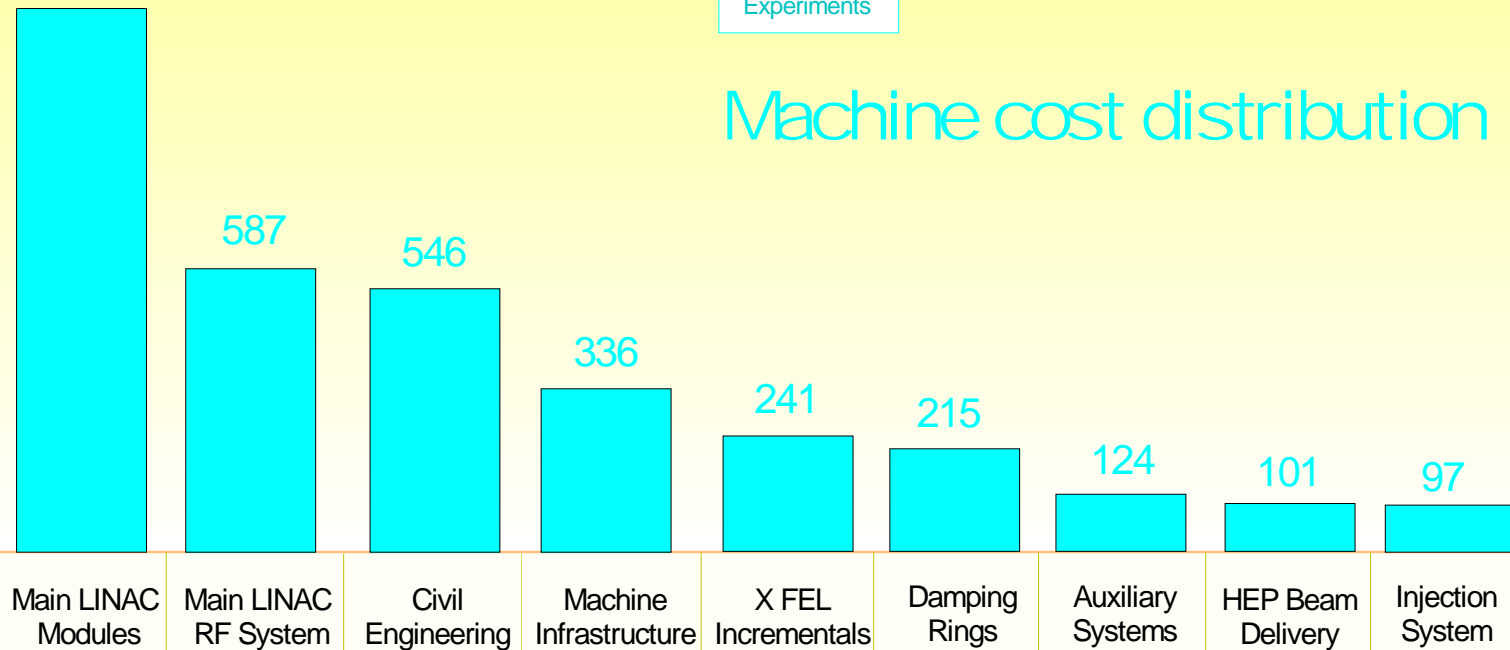

Some of the Features of SC Technology

- **The large cavity aperture and long bunch interval reduce the complexity of operations, reduce the sensitivity to ground motion, permit inter-bunch feedback and may enable increased beam current.**
- **The main linac rf systems, the single largest technical cost elements, are of comparatively lower risk.**
- **The construction of the superconducting XFEL free electron laser will provide prototypes and test many aspects of the linac.**
- **The industrialization of most major components of the linac is underway.**
- **The use of superconducting cavities significantly reduces power consumption.**

The ITRP Recommendation

- **The ITRP recommendation was presented to ILCSC & ICFA on August 19 in a joint meeting in Beijing.**
- **ICFA unanimously endorsed the ITRP's recommendation on August 20 and J. Dorfan announced the result at the IHEP Conference**
- **The ITRP recommendation was discussed and endorsed at FALC (Funding Agencies for the Linear Collider) on September 17 at CERN.**

Meeting of Funding Agencies to discuss the status and funding prospects for a linear collider of 0.5 to 1TeV. Fourth meeting held at CERN on 17 September 2004

1. The fourth meeting of representatives from CERN (President of Council and DG), Canada (NSERC), France (CNRS), Germany (BMBF), India (DAE, DST), Italy (INFN), Japan (MEXT), Korea (MOST), UK (PPARC) and the US (DOE, NSF) was held at CERN on 17 September 2004.
2. The Group received a presentation from Professor Barish, chair of the International Technology Review Panel (ITRP). He outlined the process followed to reach a recommendation on the technology for a 0.5 to 1TeV linear collider and the primary reasons for the choice of the superconducting rf technology. The Funding Agencies praised the clear choice by ICFA. This recommendation will lead to focusing of the global R& D effort for the linear collider and the Funding Agencies look forward to assisting in this process. The Funding Agencies see this recommendation to use superconducting rf technology as a critical step in moving forward to the design of a linear collider.

The ITRP Recommendation

- **The ITRP recommendation was presented to ILCSC & ICFA on August 19 in a joint meeting in Beijing.**
- **ICFA unanimously endorsed the ITRP's recommendation on August 20 and J. Dorfan announced the result at the IHEP Conference**
- **The ITRP recommendation was discussed and endorsed at FALC (Funding Agencies for the Linear Collider) on September 17 at CERN.**
- **The final report of ITRP was submitted to ILCSC on September 20 and is now available.**

What's Next?

- A **new** global design based on superconducting rf technology will be initiated by the combined warm and cold experts.
- We need to fully capitalize on the experience from SLC, FFTB, ATF and TTF as we move forward. The range of systems from sources to beam delivery in a LC is so broad that an optimized design can only emerge by pooling the expertise of all participants.
- The R&D leading to a final design for the ILC will be coordinated by an International Central Design Team, which the ITRP endorses.
- The first collaboration meeting will be at KEK in November.

The U.S. Effort on the ILC

- **Coordination of the distributed design effort is envisaged to proceed via three regional coordinators, who will be chosen by the regional steering committees in consultation with their respective funding agencies and the GDE Director.**
- **This is a major and exciting step forward taken by the international community to realize a TeV e+e- collider.**
- **Strong regional coordination is anticipated:**
 - **In North America, SLAC and FNAL are offering to act as co-coordinating centers for the regional effort.**

SLAC - Looking Forward

- **The SLAC linear collider team has embraced the ITRP process from the beginning, and is joining in the worldwide effort for R&D and design of the ILC.**
- **SLAC has been the center of the U.S. linear collider R&D effort. They bring critical skills, experience and insights essential to the U.S. effort to design the ILC.**
- **Much of the design and R&D carried out for the "warm" machine directly applies to the ILC "cold" technology design - including the Main Linac, and ranging from Beam Sources to the Interaction Region and Detector**
- **SLAC was committed to playing a leadership role for the NLC, and remains so for the ILC. They are already forming plans their technical roles in the ILC design effort**

Fermilab ILC Efforts to Date

- **NLC**
 - X-band structures fabrication
 - 5 of the 8 structures at successful NLCTA test were built by Fermilab
 - Civil/siting studies
- **SCRF**
 - Operation of 15 MeV photoinjector (identical to TTF injector)
 - SCRF cavity development for FNPL and CKM (now defunct)
- **Extremely talented scientific & engineering group in place with ability to work on warm or cold structures**



⇒ **Bottom line: By redirecting X-band and focusing SCRF more strongly on ILC, Fermilab can effectively double resources in FY05.**

Fermilab Plan

- It is essential to establish U.S. capability in the fabrication of high gradient SRF structures.
 - Fermilab commitment to provide U.S. leadership following cold decision
- Focus has been on a test facility at Fermilab (aka SMTF—Superconducting Module Test Facility).
 - Interested partners: ANL, BNL, Cornell, FNAL, JLab, LANL, LBNL, MIT, MSU, ORNL, SLAC
- Concept of a possible evolution:

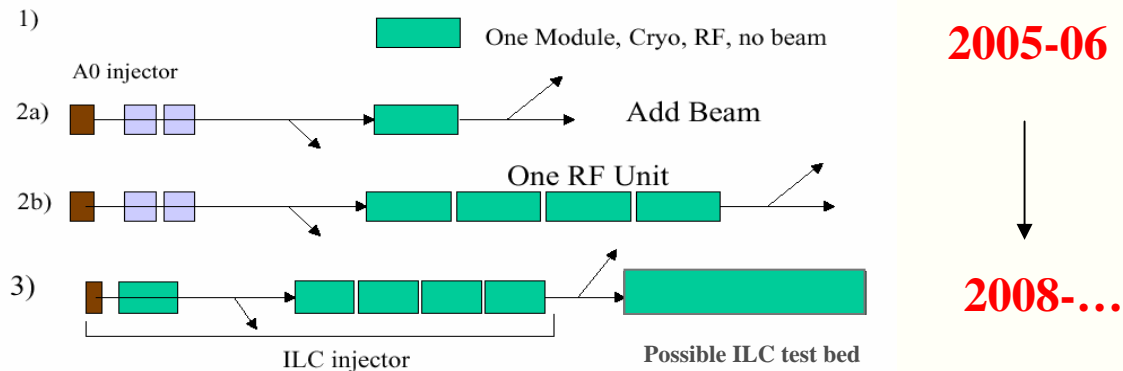

Remarks and Next Steps

- The linear collider will be designed to begin operation at 500 GeV, with a capability for an upgrade to about 1 TeV, as the physics requires. **This capability is an essential feature of the design. Therefore we urge that part of the global R&D and design effort be focused on increasing the ultimate collider energy to the maximum extent feasible. (from ITRP Exec Summary)**
- A TeV scale electron-positron linear collider is an essential part of a grand adventure that will provide new insights into the structure of space, time, matter and energy. We believe that the technology for achieving this goal is now in hand, and that the prospects for its success are extraordinarily bright. **(from ITRP Exec Summary)**